

## For Safety —

1. Operate only with instructors permission and after you have received instruction.
2. Remove jewelry, eliminate loose clothing, and confine long hair.
3. Make sure all guards are in place and operating correctly.
4. Always use proper eye protection.
5. All adjustments to the chip removal brushes, blade tension, guides, vise, or drive system should be done with the power off.
6. Be sure blade guides are properly adjusted to both the blade and the work size or vise before starting cut.
7. Adjust feed rate so blade does not bounce or plunge into work when starting the cut.
8. Be sure work is tightly clamped in the vise and properly positioned for an efficient safe cut.
9. Keep hands away from cutting area and brush away chips only when the machine is turned off.
10. If the material requires coolant be sure the system is working and the correct coolant is used.

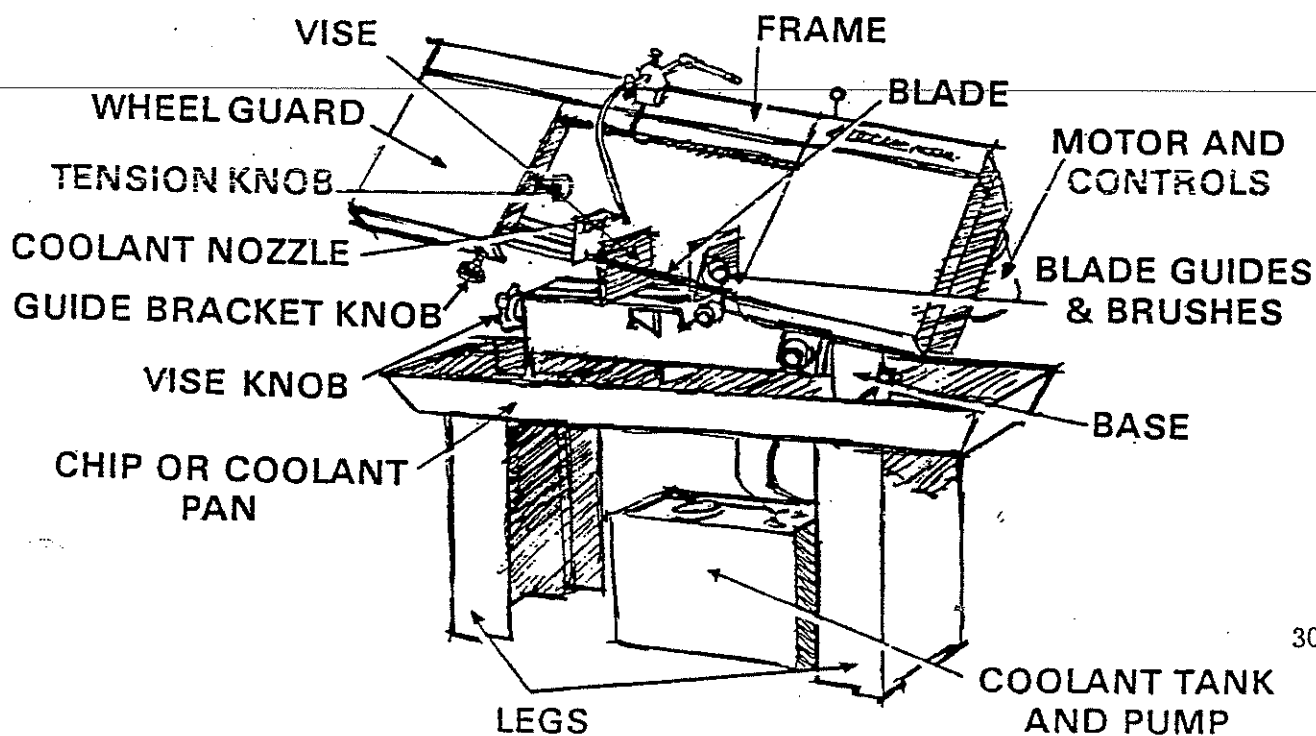

## For Safety —

1. Operate only with instructors permission and after you have received instruction.
2. Remove jewelry, eliminate loose clothing, and confine long hair.
3. Make sure all guards are in place and operating correctly.
4. Always use proper eye protection.
5. A welding helmet must be worn when welding.
6. Proper ventilation must be available.
7. Goggles must be worn when chipping slag.
8. Others in the area must be warned prior to striking an arc.
9. Gloves and proper clothing must be worn when welding.
10. Closed containers should not be welded without the instructor's permission.
11. Cables, clamps and electrode holder should be checked and working properly.
12. Screens to protect others must be in place before welding is started.

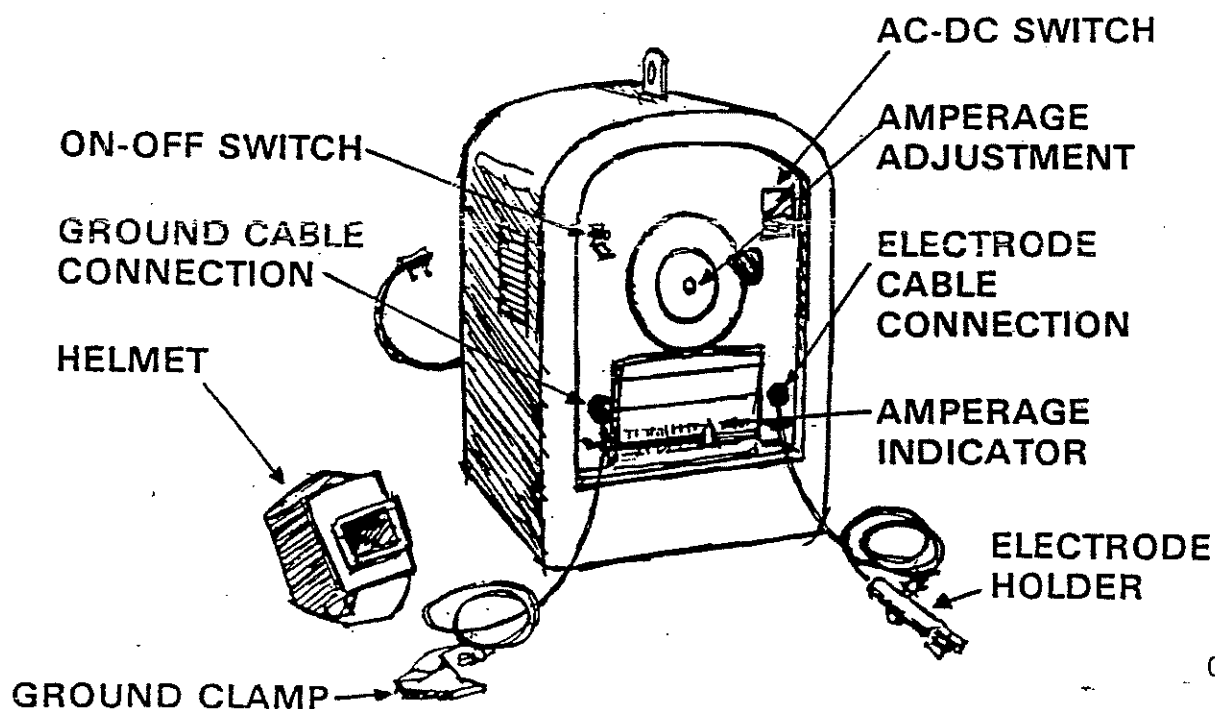

## For Safety —

1. Operate only with instructors permission and after you have received instruction.
2. Remove jewelry, eliminate loose clothing, and confine long hair.
3. Make sure all guards are in place and operating correctly.
4. Always use proper eye protection.
5. Additional protective welding clothing, including a helmet, long sleeve jacket, and gloves must be worn to prevent burns from ultraviolet and infra red rays emitted while arc welding.
6. The helmet used for TIG or MIG welding should be equipped with a minimum number twelve density shade.!
7. Be certain that the welder equipped with a high frequency stabilizing unit is installed, maintained, and used according to the recommendations of both the manufacturer and the Federal Communication Commission.
8. Never touch the tungsten electrode or MIG wire while the welder is turned on. It is electrically "hot" and can cause a serious shock.
9. Never use the high frequency when performing shield metal arc (stick electrode) welding.

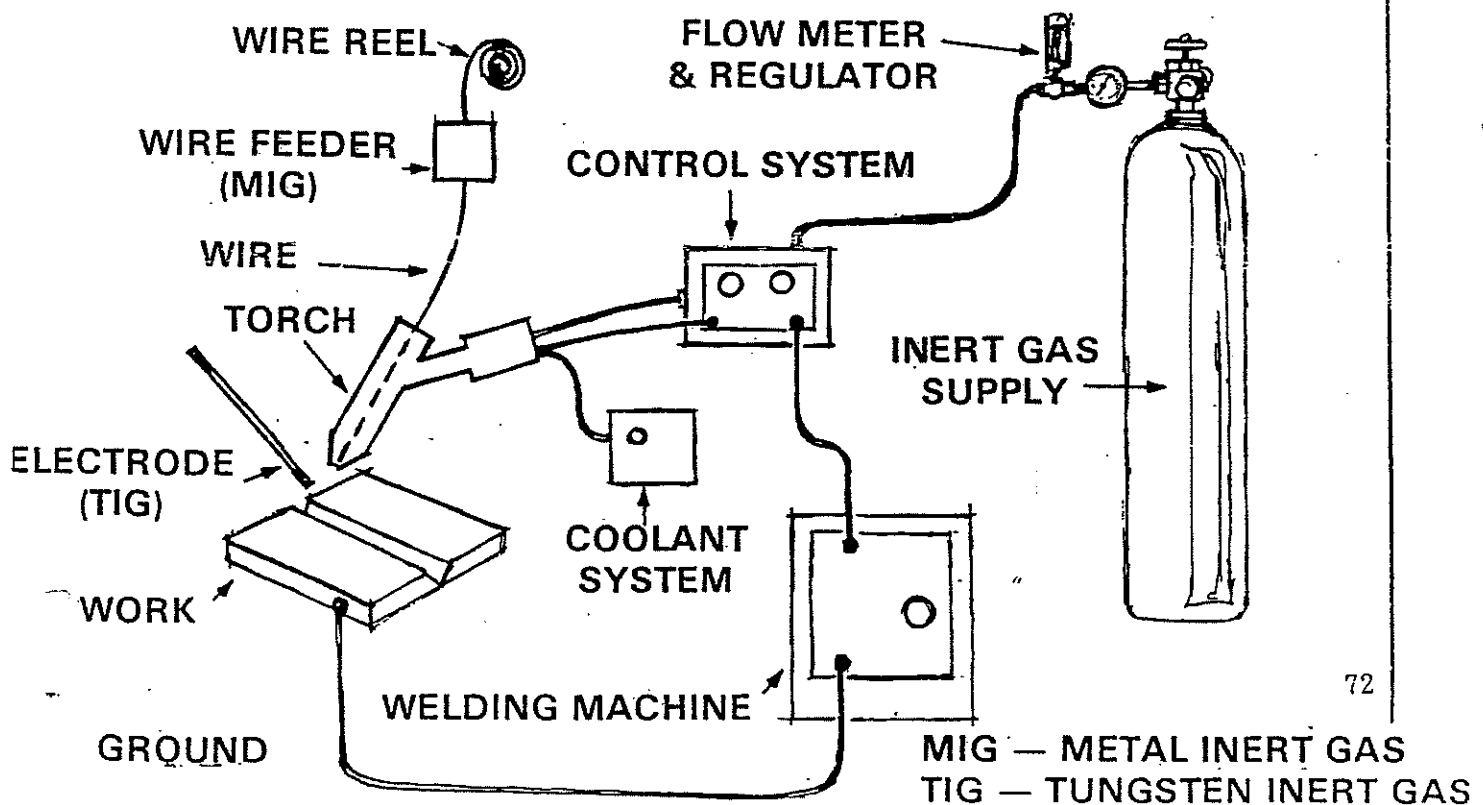

## For Safety —

1. Operate only with instructors permission and after you have received instruction.
2. Remove jewelry, eliminate loose clothing, and confine long hair.
3. Make sure all guards are in place and operating correctly.
4. Always use proper eye protection.
5. Make all adjustments except final belt tracking with the power off.
6. Make sure there is adequate strong tension on the belt and that it is not torn.
7. When changing belts make sure the new belt runs as arrows indicate.
8. The table should be adjusted to within 1/16" of the abrasive belt.
9. Keep hands clear of the abrasive belt while operating and keep material flat on the table.
10. The belt must be re-tracked if the angle of the basic machine is changed.

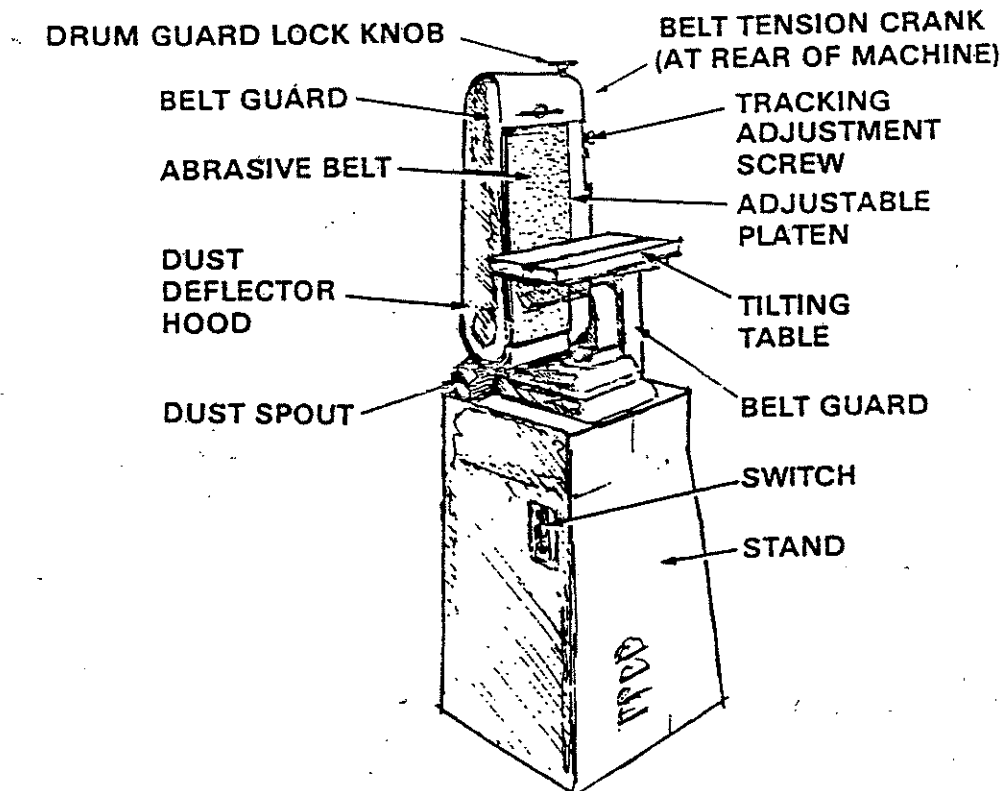

## For Safety —

1. Operate only with instructors permission and after you have received instruction.
2. Remove jewelry, eliminate loose clothing, and confine long hair.
3. Make sure all guards are in place and operating correctly.
4. Always use proper eye protection.
5. Hold material securely with vise or clamps.
6. Be sure key is removed from chuck.
7. Select a properly sharpened bit. For metal, center punch when hole is to be drilled.
8. Turn off power if work piece is caught in the drill. Do not stop by hand.
9. Adjust table or depth stop to avoid drilling into the table.
10. Select the correct speed, normally slower for metal-faster for wood. The larger the bit, the slower the speed.

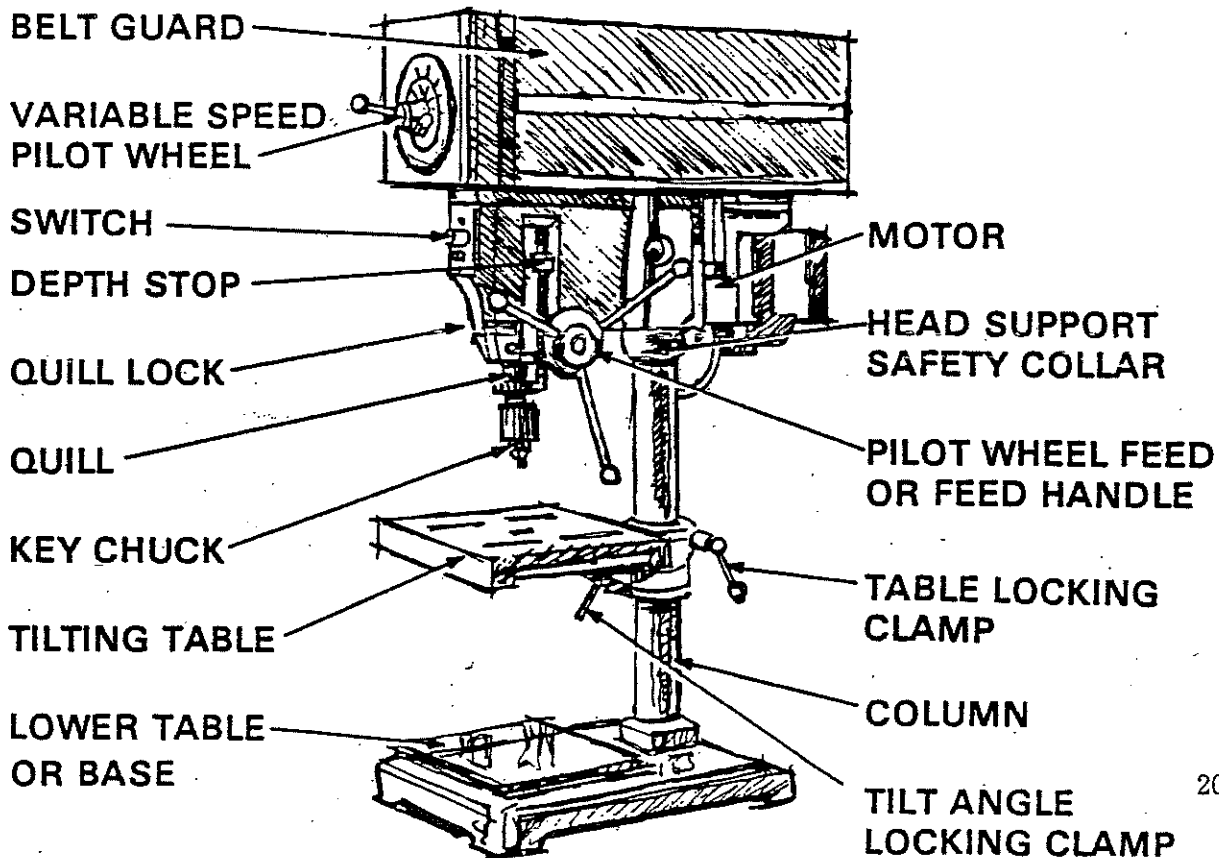

## For Safety —

1. Operate only with instructors permission and after you have received instruction.
2. Remove jewelry, eliminate loose clothing, and confine long hair.
3. Make sure all guards are in place and operating correctly.
4. Always use proper eye protection.
5. The tool rests must be adjusted to within 1/16" of the grinding wheel.
6. Spark deflectors must be adjusted to within 1/16" of the grinding wheels.
7. Do not grind on the side of the grinding wheels.
8. Stand to one side when starting the machine.
9. Discard or report grinding wheels that are excessively small or cracked.
10. Small work pieces should be held with "vise grip" type pliers.
11. Do not leave the machine until the grinding wheels have come to a full stop.

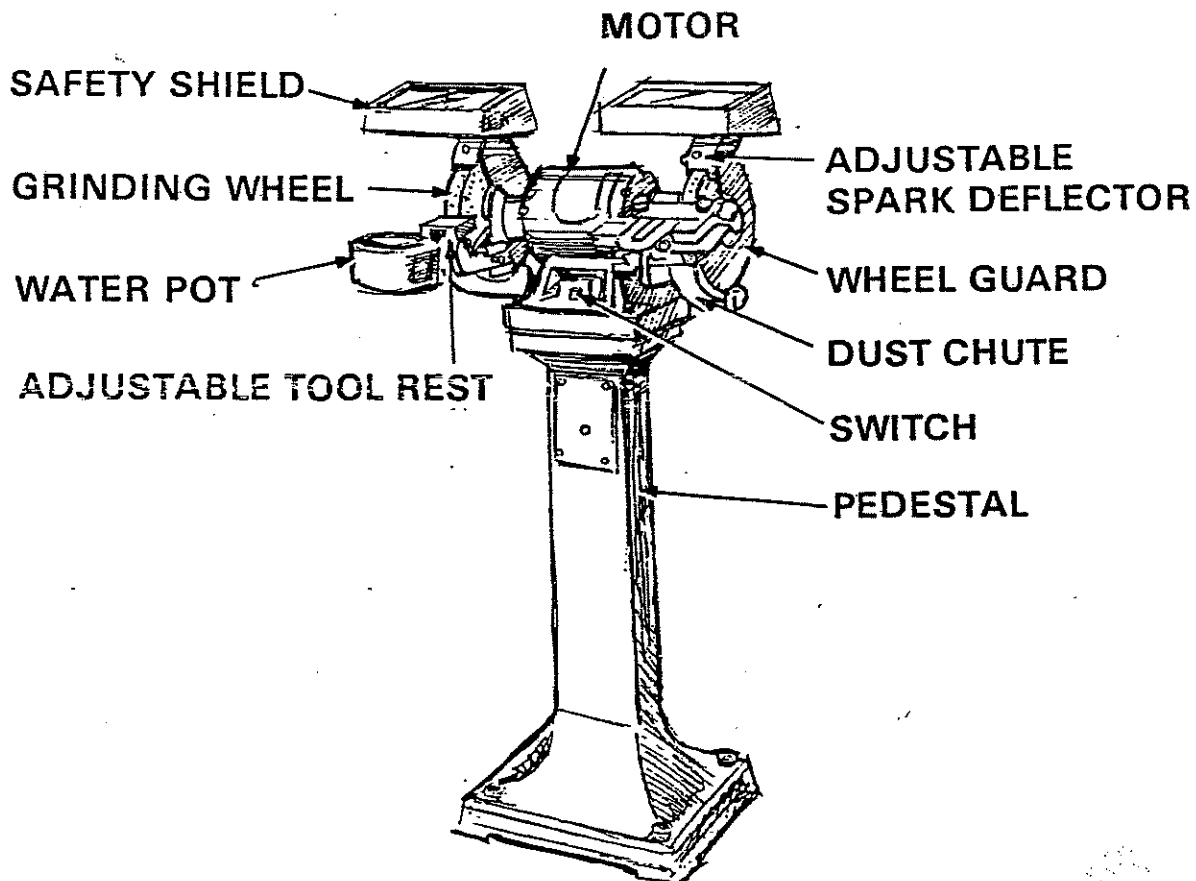

## For Safety —

1. Operate only with instructors permission and after you have received instruction.
2. Remove jewelry, eliminate loose clothing, and confine long hair.
3. Make sure all guards are in place and operating correctly.
4. Always use proper eye protection.
5. Adjust, change rolls, set stops, and properly check or assemble before operating.
6. Never bend, roll, crimp or bead metal which exceeds the capacity of the machine.
7. Work with only one piece of metal at one time, never double thickness or two pieces side by side.
8. Remove burrs from the metal before attempting to work it in the machine.
9. Keep hands away from clamps, jaws, rolls and other pinch points.
10. Do not force hit or drop-levers or handles.

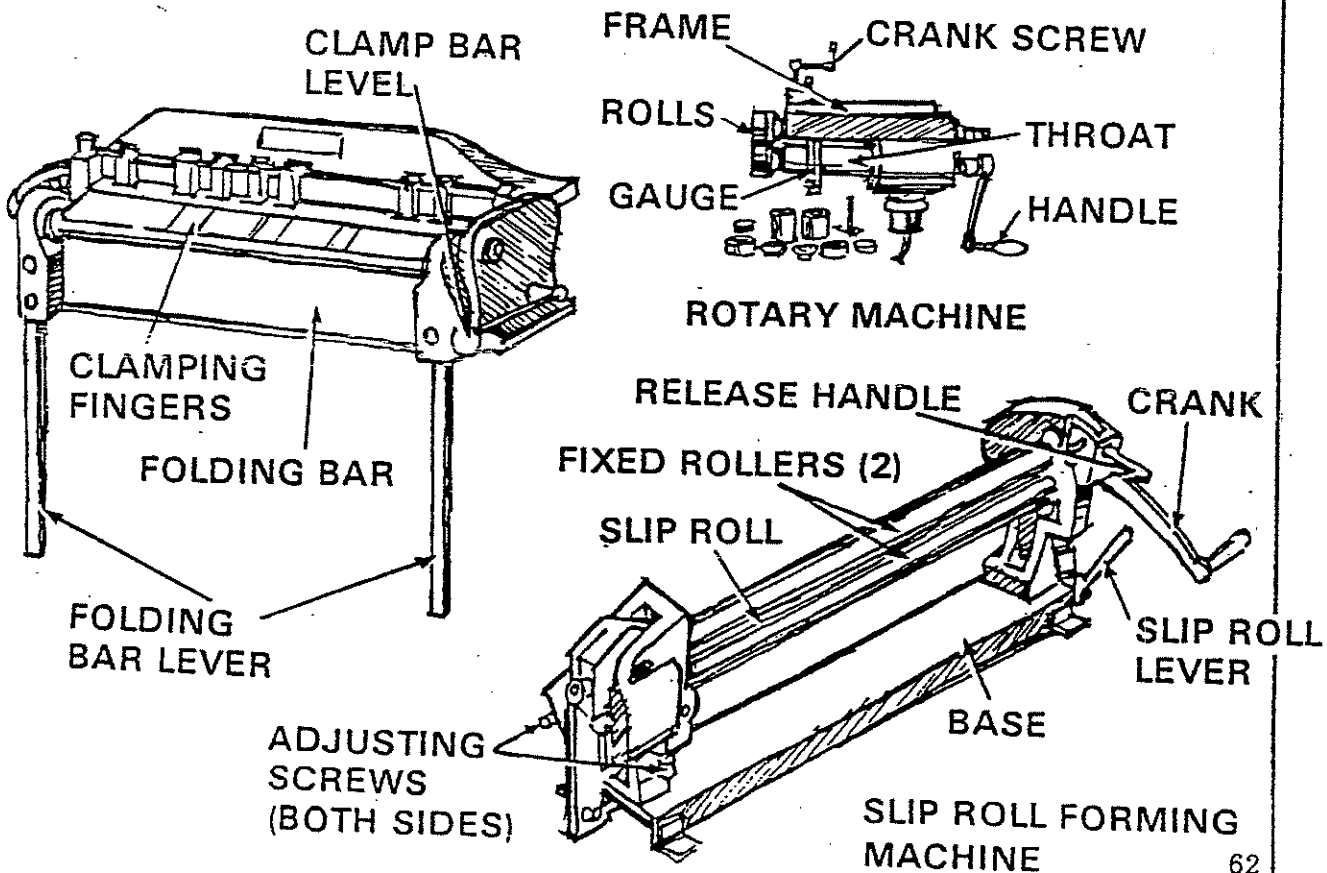

## For Safety —

1. Operate only with instructor's permission and after you have received instruction.
2. Remove jewelry, eliminate loose clothing, and confine long hair.
3. Make sure all guards are in place and operating correctly.
4. Always use proper eye protection.
5. Check the machine and the setup before operating. If needed, get a helper.
6. Never exceed the capacity of the machine.
7. Use gloves when handling large pieces of sheet metal, and remove obvious burrs from all pieces.
8. Keep fingers at least 3" away from pressure bar—hold down-guard—and blade.
9. Do not attempt to catch small pieces, allow them to fall to the floor.
10. Operate only from the front of the machine.
11. Keep area under and around the machine clean and feet out from under the foot pedal.

